

Inspection Picture of the Month:

No GFI Outlet in the Kitchen and/or Bathroom – Why is this safety item always pointed out by inspectors? A “Ground Fault Interrupter” outlet is a special receptacle that provides a safety mechanism to prevent each of us from electric shock. A GFI receptacle will sense the current flow into the outlet and the current flow out of the outlet. These 2 should match each other – if they do not, there is a “leak” in current, most likely running through the person. In this case, the GFI will immediately trip to eliminate this shock hazard. Bottom line – they are there to protect us.



George Scott

Owner-Inspector

Scott Home Inspection, LLC

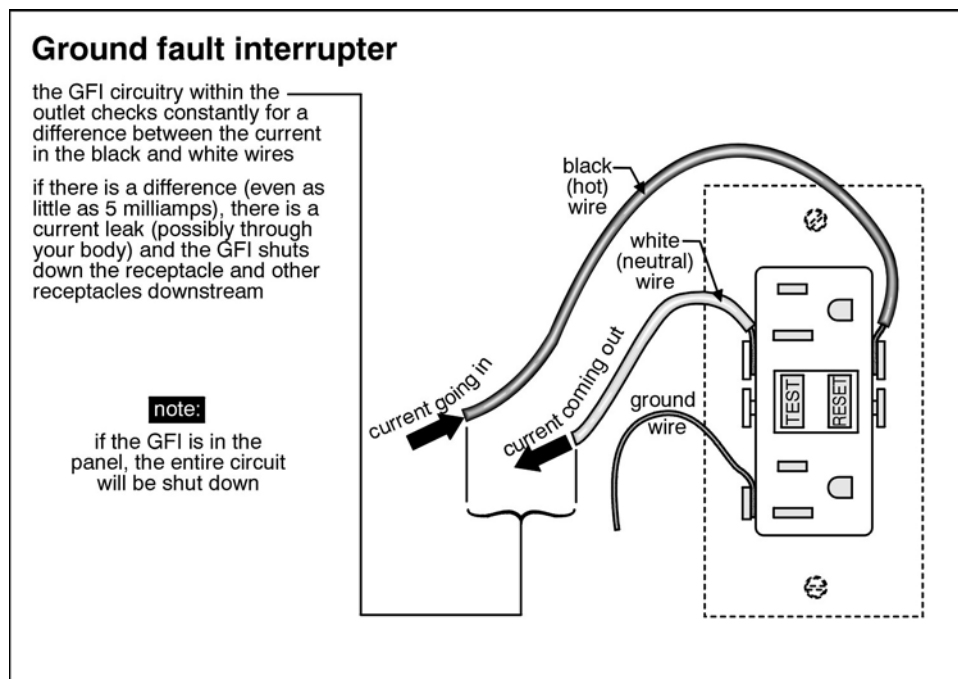

GFI Outlets are required to be installed in bathrooms, kitchens and garages. Often times, older homes do not have GFI outlets, since they were built before this code was established. In these cases, most inspectors will recommend installing GFI outlets, for safety and protection.

"You have my personal commitment that I will work to provide the best home inspection experience possible for each customer."

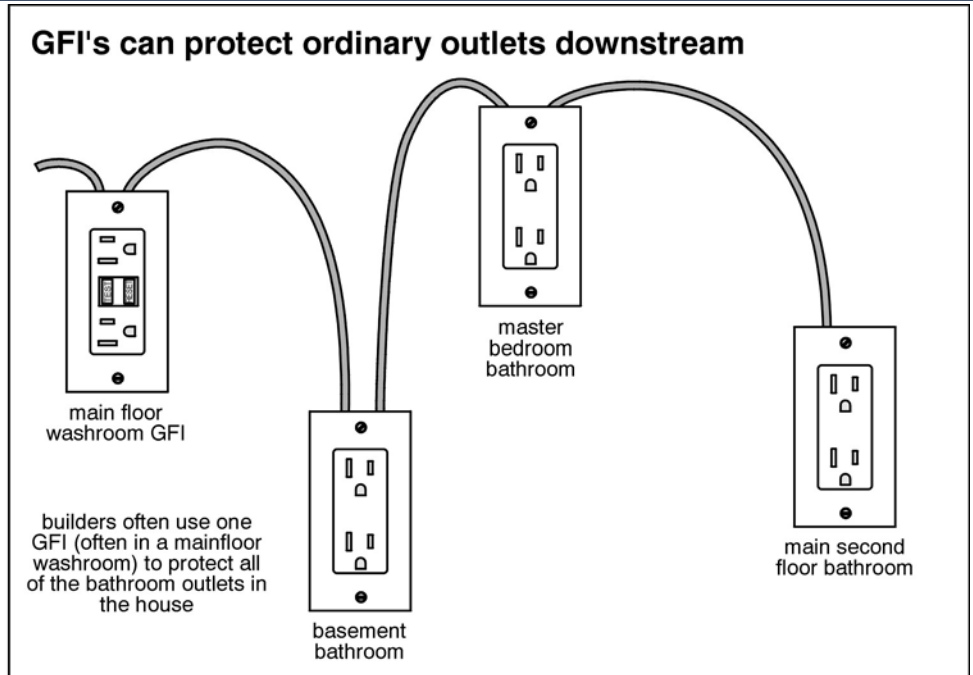

Only one GFI outlet is required, at the beginning of the series of outlets that are served. A qualified electrician should be brought in to install GFI receptacles. Ensuring the safety of homeowner's should be the first priority of any inspector. While the cost of GFI outlets is a minor expense in the home purchase process, the safety gains from this upgrade can save a life.

News:



Scott Home Inspection is now:

NWFA Certified to perform Wood Flooring inspections

This added knowledge and training will help identify problems with installation, maintenance and repair of wood floors.

Home-Tips On-Line:



Link to the following articles and informative presentations.

[*Five quick-tips to quickly recognize serious Structural problems*](#)

[*Radon - the 6 most frequently asked questions*](#)

[*Sump Pumps - Tips and Troubles*](#)

More Information about our Services:

- [*View our Services*](#)
- [*View a Sample Report*](#)
- [*Review our Fees*](#)
- [*View Schedule Availability*](#)

Contact Info:

Scott Home Inspection, LLC

970-532-2424 –or- 720-979-4960

george@scotthomeinspection.com

Visit our website!

www.scotthomeinspection.com